

**CAUTION:** Conax Technologies sealing glands should be installed by suitably qualified personnel in accordance with relevant safety rules and with proper regard to safe working practices.

Conax Technologies sealing glands have lubricant applied at the factory. Substitution of factory-supplied lubricant will affect seal integrity. Lubrication prevents thread galling and minimizes friction between mating metallic components to maximize sealing gland performance when a catalog-specified torque is applied. Weld mount models should be relubricated after the body is welded in place. If the gland has been cleaned before assembly, it should also be relubricated prior to assembly.

Lubricant should be used any time a sealing gland assembly is opened for replacement or adjustment of the probe(s), wires or sealant. By re-lubricating the gland body threads and load bearing surface of the cap, proper load transfer (sealant compression) can be achieved. See page 16 for lubrication instructions.

Conax Technologies recommends the use of thread sealant tape or dopant on NPT threads during installation of the gland to the vessel.

Flange mounted glands should be assembled prior to mounting to the vessel.

#### A Note on B Caps:

When using a sealing gland assembly with a B Cap, it is sometimes easy to confuse which NPT thread screws into the process side. If installed backwards, leakage will occur between the cap and body straight thread.

A hex notch (as shown below) has been added to the cap to simplify identification. When properly installed, the hex notch will appear on the non-process side of the assembly.

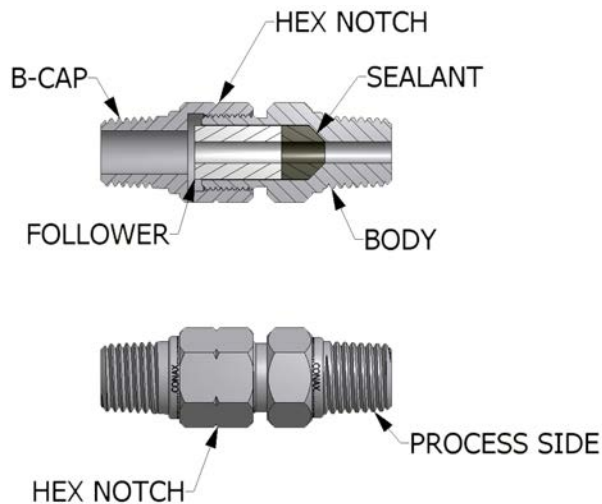

Please Note: Glands previously purchased may have "Conax" engraved on a cap hex surface in lieu of the hex notch. When properly installed the lettering will appear on the non-process side of the assembly (the cap). Please consult the factory with any questions before installing.

## Guidelines for Sealant Replacement

Conax Technologies recommends the following procedures to facilitate sealant replacement:

1. Ensure that all system pressurization has been removed before beginning sealant replacement.
2. Untorque and remove the sealing gland cap.
3. Remove the follower and sealant. Depending on the application, the element may also need to be removed.

**Follower Removal:** Tight manufacturing tolerances are used between the follower OD and the bore of the sealing gland body. As the follower is extracted, a vacuum can be created between the follower and sealant, making it difficult to remove the follower by hand. It may be necessary to clamp the exposed portion of the follower with pliers or a similar tool to gain the additional clamping force needed to remove the follower. If this is necessary, take care to avoid damage to the follower.

**Sealant Removal:** Teflon, Neoprene, and Viton sealants can generally be removed in one piece. Grafoil and Lava Sealants must be removed in multiple pieces, using a rigid "picking" instrument to break apart the sealant. During this process, be careful to avoid damage to the sealing gland body. Deep scratches or gouges may result in potential leak paths during future use of the gland assembly.

4. Thoroughly clean the internal configuration of the sealing gland body with de-ionized water or cleaning alcohol (depending on the application) to remove any sealant residue.
5. Reassemble per applicable assembly instructions.

## For Hex-Style PG Series Glands

### For assembly separate from the vessel:

1. Verify that the total probe length is sufficient for your desired immersion.
2. Thread the cap over the probe with the female thread facing the process (see diagram).
3. Thread the follower over the probe. For MPG and PG2 assemblies with bores smaller than 0.093", the follower may have a larger bore on one side. The larger bore diameter must be adjacent to the cap and the smaller bore diameter adjacent to the sealant.
4. Be sure you are using the correct sealant for your working pressure and temperature. Thread the sealant over the probe with the cone facing the process.
5. Thread the gland body over the probe.
6. Slide the sealant into the gland body.
7. Slide the follower after the sealant.
8. Push on the follower until the sealant is firmly seated.
9. Thread the cap on finger tight.
10. Secure the gland body into a vice.
11. Make the final adjustment of immersion length.
12. Using a torque wrench, tighten the cap to the specified torque (see chart).
13. The assembly is now ready for use. Apply a wrench to the gland body flats – not the cap – for mounting to the vessel.

### For assembly directly into a vessel:

1. Verify that the total probe length is sufficient for your desired immersion.
2. Mount the gland body into the vessel wall. This may be done by threading or welding, depending on the mounting style. When using a weld mount, the gland must be disassembled prior to welding to protect the sealant.
3. Thread the cap over the probe with the female thread facing the process (see diagram).
4. Thread the follower over the probe so that the follower is between the cap and the process. For MPG and PG2 assemblies with bores smaller than 0.093", the follower may have a larger bore on one side. The larger bore diameter must be adjacent to the cap and the smaller bore diameter adjacent to the sealant.
5. Be sure you are using the correct sealant for your working pressure and temperature. Thread the sealant over the probe so that the sealant is between the follower and the process, and the cone of the sealant faces the process.
6. Insert the probe through the body into the process.
7. Slide the sealant into the gland body.
8. Slide the follower after the sealant.
9. Push on the follower until the sealant is firmly seated.
10. Thread the cap on finger tight.
11. Make the final adjustment of immersion length.
12. Apply a backer wrench to the gland body flats to prevent rotation during torquing.
13. While holding the backer wrench firmly in place, use a torque wrench to tighten the cap to the specified torque (see chart).
14. The assembly is now ready for use

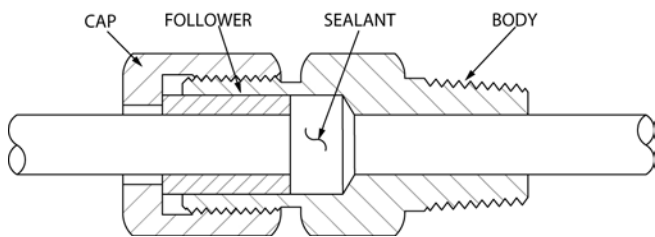

### PG Series Torque Requirements

	Neoprene/Viton		Teflon		Lava		Grafoil	
	(ft-lbs)	(N-m)	(ft-lbs)	(N-m)	(ft-lbs)	(N-m)	(ft-lbs)	(N-m)
MIC	N/O	N/O	7-9 in-lbs	0.8-1	45-50 in-lbs	5-5.6	45-50 in-lbs	5-5.6
MPG	55-60 in-lbs	6.2-6.7	55-60 in-lbs	6.2-6.7	75-80 in-lbs	8-9	55-60 in-lbs	6.2-6.7
PG2	30-35	40-47	15-20	20-27	40-45	54-61	35-40	47.6-54.4
PG4	55-60	74-81	55-60	74-81	125-140	170-190	90-100	122-136
PG5	55-60	74-82	90-100	122-136	200-220	272-299	90-100	122-136
PG6	165-170	224-231	300-325	408-442	N/O	N/O	N/O	N/O

N/O = Not Offered

### For Large Bore, Flange - Cap PG Series Glands

#### For assembly separate from the vessel:

1. Verify that the total length of the cable/probe provides sufficient length for your desired immersion and leads.
2. Thread the flange/cap over the probe (see diagram).
3. Thread the follower over the probe.
4. Be sure you are using the correct sealant for your working pressure and temperature. Thread the sealant over the probe with the cone facing the process. (Sealant may be in more than one layer.)
5. Thread the gland body over the probe.
6. Slide the sealant into the gland body.
7. Slide the follower after the sealant.
8. Push on the follower until the sealant is firmly seated.
9. Slide the flange/cap into place after the follower.
10. Insert the 6 cap screws in place and finger tighten.
11. Secure the gland body into a vice.
12. Make the final adjustment of immersion length.
13. Using a torque wrench, tighten the cap screws to the specified torque (see chart). The cap screws should be progressively tightened in the order 1-4-2-5-3-6.
14. The assembly is now ready for use. Apply a wrench to the gland body flats for mounting to the vessel.

#### For assembly directly into a vessel:

1. Verify that the total length of the cable/probe provides sufficient length for your desired immersion and leads.
2. Mount the gland body into the vessel wall. This may be done by threading or welding, depending on the mounting style. When using a weld mount, the gland must be disassembled prior to welding to protect the sealant.
3. Thread the flange/cap over the probe (see diagram).
4. Thread the follower over the probe so that the follower is between the cap and the process.
5. Be sure you are using the correct sealant for your working pressure and temperature. Thread the sealant over the probe so that the sealant is between the follower and the process, and the cone of the sealant faces the process. (Sealant may be in more than one layer.)
6. Insert the probe through the body into the process.
7. Slide the sealant into the gland body.
8. Slide the follower after the sealant.
9. Push on the follower until the sealant is firmly seated.
10. Slide the flange/cap into place after the follower.
11. Insert the 6 cap screws in place and finger tighten.
12. Make the final adjustment of immersion length.
13. Use a torque wrench to tighten the cap screws to the specified torque (see chart). The cap screws should be progressively tightened in the order 1-4-2-5-3-6.
14. The assembly is now ready for use.

## Large Bore PG Series Torque Requirements

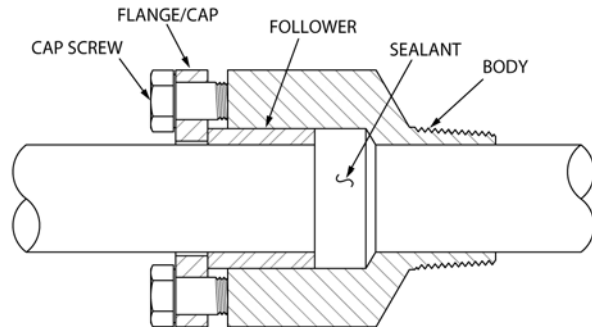

	Viton		Lava		Grafoil		Teflon
	(ft-lbs)	(N-m)	(ft-lbs)	(N-m)	(ft-lbs)	(N-m)	
<b>Standard 1-1/4 NPT</b>							
PG7-50	35	48	35	48	35	48	CF
PG7-1000	14	19	35	48	35	48	CF
PG7-75P	35	48	35	48	35	48	CF
PG7-1250	14	19	35	48	35	48	CF
PG7-100P	35	48	35	48	35	48	CF
<b>Weld Neck Mount (Weld Neck Length 1.01")</b>							
PG7(SWM7/S316L)-50P	35	48	35	48	35	48	CF
PG7(SWM7/S316L)-1000	14	19	35	48	35	48	CF
PG7(SWM7/S316L)-75P	35	48	35	48	35	48	CF
PG7(SWM7/S316L)-1250	14	19	35	48	35	48	CF
PG7(SWM7/S316L)-100P	35	48	35	48	35	48	CF

## For Hex-Style EG Series

EG series sealing glands are shipped from the factory already torqued to the correct value and ready for installation. These instructions are provided in the event you choose to disassemble and need to reassemble the gland or if you provide your own electrode. Weld mount styles are shipped untorqued, as the gland must be disassembled prior to welding to protect the sealant.

### For assembly separate from the vessel:

1. Be sure you are using the correct sealant for your working pressure and temperature.
2. Thread one ceramic insulator over the electrode (see diagram)
3. Thread the sealant over the electrode. The tapered end of the sealant should face the process. Note: EG-375 and EG-500 Lava sealants use a two-piece cone and cup design. Insert the cup first with the tapered end facing away from the process. Then insert the cone so that the tapered end fits inside the cup. The cone must face the process.
4. Thread the second ceramic insulator over the electrode.
5. Insert the insulators, sealant and electrode as assembled into the gland body until the ceramic insulator is stopped by the shoulder in the gland. Hold the electrode to prevent it from dropping through.

6. Thread the follower over the insulator. Seat the undercut edge onto the insulator shoulder.
7. Thread the cap onto the body until finger tight.
8. Secure the gland body into a vice.
9. Adjust the electrode to the correct position ensuring that the ceramic insulators are firmly seated and aligned.
10. Using a torque wrench, tighten the cap to the specified torque (see chart).
11. Install the nuts and washers on the non-process side of the assembly.
12. Mount the assembly to the vessel. Apply a wrench to the gland body flats – not the cap – when mounting to the vessel.
13. Install the nuts and washers on the process side of the assembly.
14. Make the appropriate electrical connections to the electrode using ring-tongue, lug-type or spade terminals. These are positioned between the washers. The nuts should be tightened securely.
15. The assembly is now ready for use.

### For assembly directly into a vessel:

1. Be sure you are using the correct sealant for your working pressure and temperature.
2. Mount the gland body into the vessel wall. This may be done by threading or welding, depending on the mounting style. When using a weld mount, the gland must be disassembled prior to welding to protect the sealant.
3. Thread one ceramic insulator over the electrode (see diagram).
4. Thread the sealant over the electrode. The tapered end of the sealant should face the process. Note: EG-375 and EG-500 Lava sealants use two-piece cone and cup designs. Insert the cup first with the tapered end facing away from the process. Then insert the cone so that the tapered end fits inside the cup. The cone must face the process.
5. Thread the second ceramic insulator over the electrode.
6. Insert the insulators, sealant and electrode as assembled into the cap thread end of the gland body until the ceramic insulator is stopped by the shoulder in the gland. Hold the electrode to prevent it from dropping through.
7. Thread the follower over the insulator. Seat the undercut edge onto the insulator shoulder.
8. Thread the cap onto the body until finger tight.
9. Adjust the electrode to the correct position ensuring that the ceramic insulators are firmly seated and aligned.
10. Apply a backer wrench to the gland body flats to prevent rotation during torquing.
11. While holding the backer wrench firmly in place, use a torque wrench to tighten the cap to the specified torque (see chart).
12. Install the nuts and washers on the non-process side of the assembly.
13. Install the nuts and washers on the process side of the assembly.
14. Make the appropriate electrical connections to the electrode using ring-tongue, lug-type or spade terminals. These are positioned between the washers. The nuts should be tightened securely.
15. The assembly is now ready for use.

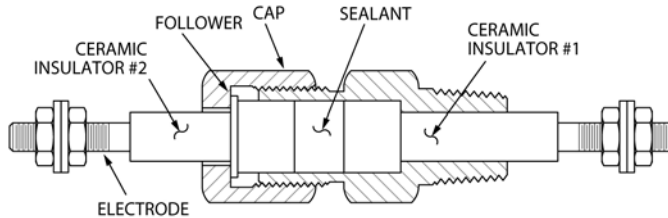
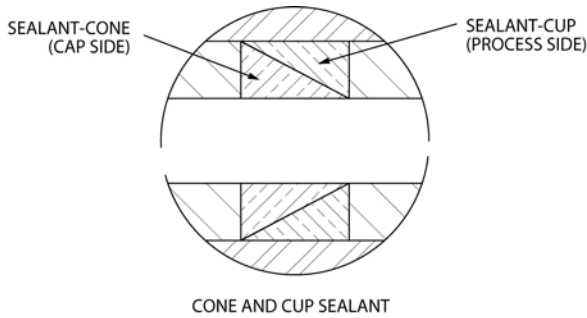

## EG Series Torque Requirements

	Neoprene/Teflon/Viton		Lava	
	(ft-lbs)	(N-m)	(ft-lbs)	(N-m)
EG-093	17-20	23-27	10-12	13-16
EG-125	25-30	34-40	25-30	34-40
EG-187	25-30	34-40	25-30	34-40
EG-250	40-45	54-61	60-65	81-88
EG-312	35-40	47-54	50-55	68-74
EG-375	50-55	68-74	180-200	244-272
EG-500	50-55	68-74	180-200	244-272

## For EG-750 (Flange-Cap)

EG series sealing glands are shipped from the factory already torqued to the correct value and ready for installation. These instructions are provided in the event you choose to disassemble and need to reassemble the gland or if you provide your own electrode. When using a weld mount, the gland must be disassembled prior to welding to protect the sealant.

### For assembly separate from the vessel:

1. Be sure you are using the correct sealant for your working pressure and temperature.
2. Thread one ceramic insulator over the electrode (see diagram). Note: the longer insulator must be used on the body side (toward the process).
3. Thread the sealant over the electrode. The tapered end of the sealant should face the process. Note: Lava sealants use two-piece cone and cup designs. Insert the cup first with the tapered end facing the process. Then insert the cone so that the tapered end fits inside the cup. The cone must face the process.
4. Thread the short ceramic insulator over the electrode.
5. Insert the insulators, sealant and electrode as assembled into the gland body until the ceramic insulator is stopped by the shoulder in the gland. Hold the electrode to prevent it from dropping through.

6. Slide the flange/cap into place after the insulator.
7. Insert the 6 cap screws in place and finger tighten.
8. Secure the gland body into a vice.
9. Adjust the electrode to the correct position ensuring that the ceramic insulators are firmly seated and aligned.
10. Use a torque wrench to tighten the cap screws to 10-12 ft-lbs (13-16 N-m) per bolt for Teflon or 25-30 ft-lbs (34-40 N-m) per bolt for Lava. The cap screws should be progressively tightened in the order 1-4-2-5-3-6.
11. Install the nuts and washers on the non-process side of the assembly.
12. Mount the assembly to the vessel. Apply a wrench to the gland body flats when mounting to the vessel.
13. Install the nuts and washers on the process side of the assembly.
14. Make the appropriate electrical connections to the electrode using ring-tongue, lug-type or spade terminals. These are positioned between the washers. The nuts should be tightened securely.
15. The assembly is now ready for use.

### For assembly directly into a vessel:

1. Be sure you are using the correct sealant for your working pressure and temperature.
2. Mount the gland body into the vessel wall. This may be done by threading or welding, depending on the mounting style. When using a weld mount, the gland must be disassembled prior to welding to protect the sealant.
3. Thread one ceramic insulator over the electrode (see diagram). Note: the longer insulator must be used on the body side (toward the process).
4. Thread the sealant over the electrode. The tapered end of the sealant should face the process. Note: Lava sealants use two-piece cone and cup designs. Insert the cup first with the flat side facing the process. Then insert the cone so that the tapered end fits inside the cup. The cone must face the process.
5. Thread the short ceramic insulator over the electrode.
6. Insert the insulators, sealant and electrode as assembled into the cap thread end of the gland body until the ceramic insulator is stopped by the shoulder in the gland. Hold the electrode to prevent it from dropping through.
7. Slide the flange/cap into place after the insulator.
8. Insert the 6 cap screws in place and finger tighten.
9. Adjust the electrode to the correct position ensuring that the ceramic insulators are firmly seated and aligned.
10. Use a torque wrench to tighten the cap screws to 10-12 ft-lbs (13-16 N-m) per bolt for Teflon or 25-30 ft-lbs (34-40 N-m) per bolt for Lava. The cap screws should be progressively tightened in the order 1-4-2-5-3-6.
11. Install the nuts and washers on the non-process side of the assembly.
12. Install the nuts and washers on the process side of the assembly.



- Make the appropriate electrical connections to the electrode using ring-tongue, lug-type or spade terminals. These are positioned between the washers. The nuts should be tightened securely.
- The assembly is now ready for use.

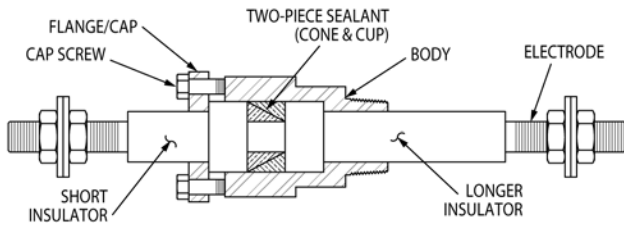

Figure 3

### For Hex-Style EGT/HEGPK Series:

EGT and HEGPK series sealing glands are shipped from the factory already torqued to the correct value and ready for installation. These instructions are provided in the event you choose to disassemble and need to reassemble the gland or if you provide your own electrode. When using a weld mount, the gland must be disassembled prior to welding to protect the Teflon sealant.

#### For assembly separate from the vessel:

- Thread the Teflon/PEEK sealant/insulator over the electrode.  
The tapered end must face the process (see diagram).
- Insert the sealant/insulator and electrode as assembled into the gland body until the sealant/insulator is stopped by the shoulder in the gland. Hold the electrode to prevent it from dropping through the body.
- Insert the follower.
- Thread the cap onto the body until finger tight.
- Secure the gland body into a vice.
- Adjust the electrode to the correct position ensuring that the sealant/insulator is firmly seated.
- Using a torque wrench, tighten the cap to the specified torque (see chart).
- Install the nuts and washers on the non-process side of the assembly.
- Mount the assembly to the vessel. Apply a wrench to the gland body flats – not the cap – when mounting to the vessel.
- Install the nuts and washers on the process side of the assembly.
- Make the appropriate electrical connections to the electrode using ring-tongue, lug-type or spade terminals. These are positioned between the washers. The nuts should be tightened securely.
- The assembly is now ready for use.

#### For assembly directly into a vessel:

- Mount the gland body into the vessel wall. This may be done by threading or welding, depending on the mounting style. When using a weld mount, the gland must be disassembled prior to welding to protect the sealant.
- Thread the Teflon/PEEK sealant/insulator over the electrode. The tapered end must face the process (see diagram).
- Insert the sealant/insulator and electrode as assembled into the cap thread end of the gland body until the sealant/insulator is stopped by the shoulder in the gland. Hold the electrode to prevent it from dropping through the body.
- Insert the follower.
- Thread the cap onto the body until finger tight.
- Adjust the electrode to the correct position ensuring that the sealant/insulator is firmly seated and aligned.
- Apply a backer wrench to the gland body flats to prevent rotation during torquing.
- While holding the backer wrench firmly in place, use a torque wrench to tighten the cap to the specified torque (see chart).
- Install the nuts and washers on the non-process side of the assembly.
- Install the nuts and washers on the process side of the assembly.
- Make the appropriate electrical connections to the electrode using ring-tongue, lug-type or spade terminals. These are positioned between the washers. The nuts should be tightened securely.
- The assembly is now ready for use.

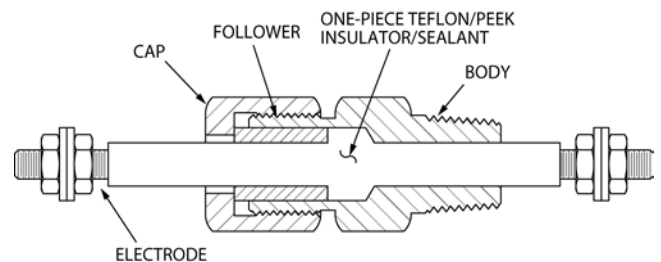

### EGT/HEGPK Series Torque Requirements

	Teflon		PEEK	
	(ft-lbs)	(N-m)	(ft-lbs)	(N-m)
EGT-093	5-6	6-8	—	—
EGT/HEGPK-125	10-15	13-20	30	40
EGT/HEGPK-187	25-30	34-40	70	95
EGT/HEGPK-250	25-30	34-41	70	95
EGT/HEGPK-375	35-40	47-54	180	244
EGT/HEGPK-500	35-40	47-54	180	244
EGT-750	75-80	102-108	—	—

## For EGT-1000 (Flange-Cap)

EGT series sealing glands are shipped from the factory already torqued to the correct value and ready for installation. These instructions are provided in the event you choose to disassemble and need to reassemble the gland or if you provide your own electrode. When using a weld mount, the gland must be disassembled prior to welding to protect the Teflon sealant.

### For assembly separate from the vessel:

1. Thread the Teflon sealant/insulator over the electrode. The tapered end must face the process (see diagram).
2. Insert the sealant/insulator and electrode as assembled into the gland body until the sealant/insulator is stopped by the shoulder in the gland. Hold the electrode to prevent it from dropping through the body.
3. Insert the follower.
4. Slide the flange/cap into place after the follower.
5. Thread the 6 cap screws in place and finger tighten.
6. Secure the gland body into a vice.
7. Adjust the electrode to the correct position ensuring that the sealant/insulator is firmly seated.
8. Use a torque wrench to tighten the cap screws to 54-60 in-lbs (6-7 N-m) per bolt. The cap screws should be progressively tightened in the order 1-4-2-5-3-6.
9. Install the nuts and washers on the non-process side of the assembly.
10. Mount the assembly to the vessel. Apply a wrench to the gland body flats when mounting to the vessel.
11. Install the nuts and washers on the process side of the assembly.
12. Make the appropriate electrical connections to the electrode using ring-tongue, lug-type or spade terminals. These are positioned between the washers. The nuts should be tightened securely.
13. The assembly is now ready for use.

### For assembly directly into a vessel:

1. Mount the gland body into the vessel wall. This may be done by threading or welding, depending on the mounting style. When using a weld mount, the gland must be disassembled prior to welding to protect the sealant.
2. Thread the Teflon sealant/insulator over the electrode. The tapered end must face the process (see diagram).
3. Insert the sealant/insulator and electrode as assembled into the gland body until the sealant/insulator is stopped by the shoulder in the gland. Hold the electrode to prevent it from dropping through the body.
4. Insert the follower.
5. Slide the flange/cap into place after the follower.
6. Insert the 6 cap screws in place and finger tighten.
7. Adjust the electrode to the correct position ensuring that the sealant/insulator is firmly seated and aligned.

8. Use a torque wrench to tighten the cap screws to 54-60 in-lbs (6-7 N-m) per bolt. The cap screws should be progressively tightened in the order 1-4-2-5-3-6.
9. Install the nuts and washers on the non-process side of the assembly.
10. Install the nuts and washers on the process side of the assembly.
11. Make the appropriate electrical connections to the electrode using ring-tongue, lug-type or spade terminals. These are positioned between the washers. The nuts should be tightened securely.
12. The assembly is now ready for use.

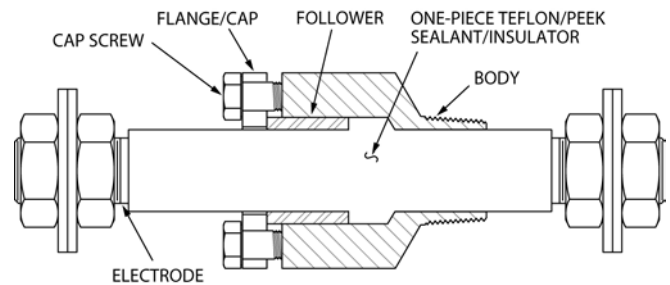

## For MK Series

### For assembly separate from the vessel:

1. Verify that the total length of the wire/probe provides sufficient length for your desired immersion and leads.
2. Thread the cap over the probe with the male thread facing the process (see diagram).
3. Thread the ferrule over the probe with the cone facing the process.
4. Thread the gland body over the probe.
5. Slide the ferrule into the gland body.
6. Thread the cap on finger tight.
7. Secure the gland body into a vice.
8. Make the final adjustment of immersion length.
9. Using a torque wrench, tighten the cap to the specified torque (see chart).
10. The assembly is now ready for use. Apply a wrench to the gland body flats for mounting to the vessel.

### For assembly directly into a vessel:

1. Verify that the total length of the wire/probe provides sufficient length for your desired immersion and leads.
2. Mount the gland body into the vessel wall.
3. Thread the cap over the probe with the male thread facing the process (see diagram).
4. Thread the ferrule over the probe with the cone facing the process.
5. Insert the probe through the body into the process.
6. Insert the ferrule into the gland body.
7. Thread the cap on finger tight.
8. Make the final adjustment of immersion length.
9. Apply a backer wrench to the gland body flats to prevent rotation during torquing.

- While holding the backer wrench firmly in place, use a torque wrench to tighten the cap to the specified torque (see chart).
- The assembly is now ready for use.

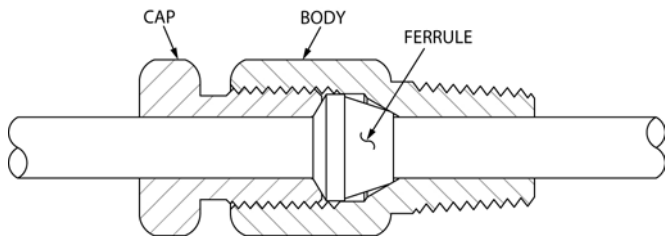

### MK Series Torque Requirements

Catalog Number	Torque	
	(ft-lbs)	(N-m)
MK-062-A	10	14
MK-125-A	12	16
MK-187-A	18	24
MK-250-A	30	41
MK-375-A	50	68

### TG Series:

For Models TG-14-1; TG-20, 2 & 4 hole; TG-24, 2 & 4 hole, all MTGs

#### For assembly separate from the vessel:

- Verify that the total length of wire provides a sufficient length for your desired immersion and leads.
- Thread the cap over the wires.
- Thread the follower over the wires so that keyway faces the cap.
- Thread on insulator #4 (see diagram).
- Thread on insulator #3.
- Be sure you are using the correct sealant for your working pressure and temperature. Thread on the sealant so that the cone of the sealant faces the process.
- Thread on insulator #2
- Thread insulator #1 over the wire.
- Pass the process side of the wires through the body.
- Slide the insulators and sealant into the body.
- Slide the follower on over insulator #4 and insulator #3 until it completely covers insulator #3.
- Push on the follower until the sealant and insulators are firmly seated. Be careful not to crimp the wires between the insulators and sealant.
- Align the follower and body to create a full keyway.
- Place the pin in the keyway.
- Thread the cap on finger tight.
- Secure the gland body into a vice.
- Adjust the wires to the correct position.

- Using a torque wrench, tighten the cap to the specified torque (see chart).
- The assembly is now ready for use. Apply a wrench to the gland body flats - not the cap - for mounting to the vessel.

#### For assembly directly into a vessel:

- Verify that the total length of wire provides a sufficient length for your desired immersion and leads.
- Mount the gland body into the vessel wall. This may be done by threading or welding, depending on the mounting style. When using a weld mount, the gland must be disassembled prior to welding to protect the sealant.
- Thread the cap over the wires.
- Thread the follower over the wires so that keyway faces the cap.
- Thread on insulator #4 (see diagram).
- Thread on insulator #3.
- Be sure you are using the correct sealant for your working pressure and temperature. Thread on the sealant so that the cone of the sealant faces the process.
- Thread on insulator #2.
- Thread insulator #1 over the wire.
- Pass the process side of the wires through the body.
- Slide the insulators and sealant into the body.
- Slide the follower on over insulator #4 and insulator #3 until it completely covers insulator #3.
- Push on the follower until the sealant and insulators are firmly seated. Be careful not to crimp the wires between the insulators and sealant.
- Align the follower and body to create a full keyway.
- Place the pin in the keyway.
- Thread the cap on finger tight.
- Adjust the wires to the correct position.
- Apply a backer wrench to the gland body wrench flats to prevent rotation during torquing.
- While holding the backer wrench firmly in place, use a torque wrench to tighten the cap to the specified torque (see chart).
- The assembly is now ready for use.

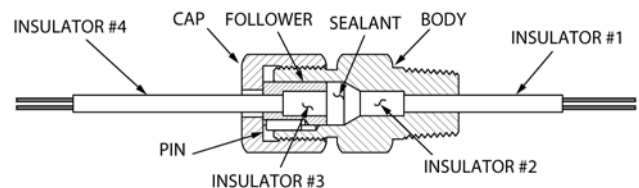

### TG Series:

For Models TG-8-2; TG-14, 2-8 hole; TG-18, 6 & 8 hole; TG-20, 6-16 hole

#### For assembly separate from the vessel:

- Verify that the total length of wire provides a sufficient length for your desired immersion and leads.
- Thread insulator #4 (see diagram) over the wire.
- Thread the cap over the wire.
- Thread the follower over the wires so that the keyway faces the cap.

5. Thread on insulator #3.
6. Be sure you are using the correct sealant for your working pressure and temperature. Thread on the sealant with the cone facing the process.
7. Thread on insulator #2.
8. Insert the wires and insulator assembly through the process end of the gland body.
9. Thread insulator #1 over the wire until the insulator is stopped by the body shoulder.
10. Slide insulator #2 into the body until the insulator is stopped by the body shoulder.
11. Slide the sealant, followed by the follower, into the body.
12. Push on the follower until the sealant and insulators are firmly seated. Be careful not to crimp the wires between the insulators and sealant.
13. Slide insulator #4 so that it butts against the follower.
14. Align the follower and body to create a full keyway.
15. Place the pin in the keyway.
16. Thread the cap on finger tight.
17. Secure the gland body into a vice.
18. Adjust the wires to the correct position.
19. Using a torque wrench, tighten the cap to the specified torque (see chart).
20. The assembly is now ready for use. Apply a wrench to the gland body flats – not the cap – for mounting to the vessel.

**For assembly directly into a vessel:**

1. Verify that the total length of wire provides a sufficient length for your desired immersion and leads.
2. Mount the gland body into the vessel wall. This may be done by threading or welding, depending on the mounting style. When using a weld mount, the gland must be disassembled prior to welding to protect the sealant.
3. Thread insulator #4 (see diagram) over the wire.
4. Thread the cap over the wire.
5. Thread the follower over the wires so that the keyway faces the cap.
6. Thread on insulator #3.

7. Be sure you are using the correct sealant for your working pressure and temperature. Thread on the sealant with the cone facing the process.
8. Thread on insulator #2.
9. Insert the wires and insulator assembly through the process end of the gland body.
10. Thread insulator #1 over the wire from the inside of the vessel and through the process side of the gland body until the insulator is stopped by the body shoulder.
11. Slide insulator #2 into the body until the insulator is stopped by the body shoulder.
12. Slide the sealant, followed by the follower, into the body.
13. Push on the follower until the sealant and insulators are firmly seated. Be careful not to crimp the wires between the insulators and sealant.
14. Slide insulator #4 so that it butts against the follower.
15. Align the follower and body to create a full keyway.
16. Place the pin in the keyway.
17. Thread the cap on finger tight.
18. Adjust the wires to the correct position.
19. Apply a backer wrench to the gland body wrench flats to prevent rotation during torquing.
20. While holding the backer wrench firmly in place, use a torque wrench to tighten the cap to the specified torque (see chart).
21. The assembly is now ready for use.

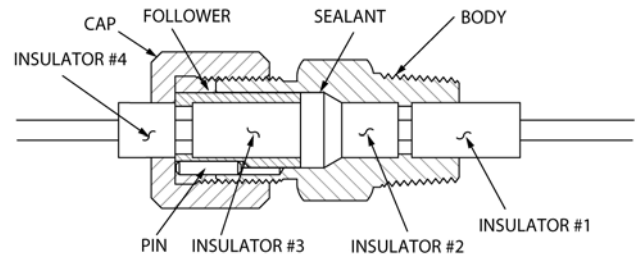

**TG Series Torque Requirements**

Gland	Number of Holes	Neoprene		Viton		Teflon		Lava	
		(ft-lbs)	(N-m)	(ft-lbs)	(N-m)	(ft-lbs)	(N-m)	(ft-lbs)	(N-m)
MTG-24	2,4	20-25	27-34	20-25	27-34	20-25	27-34	30-35	40-47
MTG-20	2,4	20-25	27-34	20-25	27-34	20-25	27-34	30-35	40-48
MTG-14	1	20-25	27-34	20-25	27-34	20-25	27-34	30-35	40-49
TG-24	2,4	25-30	34-40	25-30	34-40	30-35	40-48	40-45	54-61
TG-20	2,4	25-30	34-40	25-30	34-40	30-35	40-48	40-45	54-61
TG-20	6,8	45-50	61-68	45-50	61-68	50-55	68-74	125-140	170-190
TG-20	16	75-85	102-115	75-85	102-115	75-85	102-115	200-220	272-299
TG-18	6,8	45-50	61-68	45-50	61-68	50-55	68-74	125-140	170-190
TG-14	1	25-30	34-40	25-30	34-40	30-35	40-48	40-45	54-61
TG-14	2,3,4	45-50	61-68	45-50	61-68	50-55	68-74	125-140	170-190
TG-14	6,8	75-85	102-115	75-85	102-115	75-85	102-115	200-220	272-299
TG-8	2	75-85	102-115	75-85	102-115	75-85	102-115	200-220	272-299
TG-20	24	NA	NA	95-100	129-136	95-100	129-136	300-310	408-422



**Model TGF – TG Assembly with High Temperature Wire**  
**Model TG24T – TG Assembly with 24AWG Teflon**  
**Insulated Wire**

Model TGF and TG24T series sealing glands are shipped from the factory already torqued to the correct value and ready for installation. These instructions are provided for installation of the assembled gland. In the event you choose to disassemble and need to reassemble the gland, see the instructions for the MHC Series.

When using a weld mount, the gland must be disassembled prior to welding to protect the sealant.

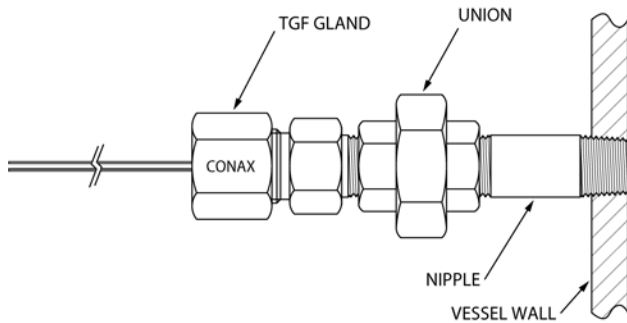

**Recommended Method Using a Nipple-Union**

*Required Materials: Pipe Nipple, Schedule 40, Carbon Steel or Stainless Steel Union, 150 lb., Carbon Steel or Stainless Steel*

For longer length lead wires, this mounting method eliminates additional stress and potential wire entanglement caused by the rotation of the wires during the mounting operation.

1. Install the nipple and half union assembly into the vessel wall.
2. Uncoil and straighten the leads on the pressure side of the gland.
3. Thread the mating half of the union over the leads.
4. Assemble the union onto the mounting thread of the sealing gland. Use the gland body flats to hold/secure the gland while mating the gland with the union.

**For High Density Assemblies – HD Series**

1. High Density assemblies use a number of different gland types. Select the appropriate gland for your application.
2. Secure the gland body into the vessel wall. The remaining gland parts are best assembled on a flat surface such as a work table or a clean floor.
3. Install the seat and insulators if applicable, depending on the gland type (see instructions for that gland type).
4. Install the sealant.
5. Install the follower and pin if applicable.
6. Insert the leads through the gland body and insert the high density assembly (as now assembled) into the body until the seat or insulator is firmly seated. Position the stainless steel sheath so that an approximately equal amount extends on each side of the gland.

5. Pass the leads through the nipple-union assembly mounted on the vessel wall.
6. Position the two parts of the union and assemble the nipple-union assembly.
7. Remove wire markers on the process side after installation, as the adhesive-backed material could contaminate the process (depending on the application).

**TGF Series Torque Requirements**

Catalog Number	Number of Holes	Viton-Teflon	
		(ft-lbs)	(N-m)
MTG-F	2,4	72-78 in-lbs	8-9
TG-24F	2,4	10-12	13-16
TG-20F	2,4	10-12	13-16
TG-20F-14	2,4	25-30	34-40
TG-20F	6,8	25-30	34-40
TG-20F	16	60-65	81-88
TG-20F	24	70-75	95-102

**TG24T Series Torque Requirements**

Catalog Number	Number of Holes	Torque for Teflon Sealant w/ T/C Wire Except Type T		Torque for Grafoil Sealant and Teflon w/ Copper or Type T Wire	
		(ft-lbs)	(N-m)	(ft-lbs)	(N-m)
MTG-24T	2,4	20-25	24-34	72-78 in-lbs	8-9
TTG-24T	2,4	30-35	40-47	10-12	13-16
TG-24T	6,8	50-55	67-74	25-30	34-40
TG-24T	12,16	75-85	102-115	60-65	81-88
TG-24T	24	95-100	129-136	70-75	95-102

**Optional Method for TG24T**

1. Uncoil and straighten the leads on the pressure side.
2. Pass the leads through the mounting thread port on the vessel.
3. Screw/tighten the gland into the vessel. Apply the wrench to the gland body flats, not the cap.
4. Remove wire markers on the process side after installation, as the adhesive-backed material could contaminate the process (depending on the application).

7. Thread the cap on finger tight.
8. Apply a backer wrench to the gland body flats. Using a torque wrench, apply the appropriate torque for that gland style.
9. The assembly is now ready for use.

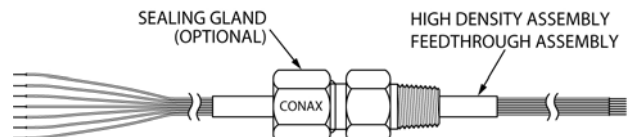

## MHC Series:

### For assembly separate from the vessel:

1. Verify that the total length of wire/probes provides a sufficient length for your desired immersion and leads.
2. Thread the cap over the wires.
3. Thread the follower over the wires so that the keyway faces the cap.
4. Thread on insulator #2 (see diagram).
5. Be sure you are using the correct sealant for your working pressure and temperature. Thread on the sealant with the cone facing the process.
6. Thread on insulator #1.
7. Pass the process side of the wires/probes through the body.
8. Slide the insulators, sealant and follower into the body.
9. Push on the follower until the sealant and insulators are firmly seated. For wire assemblies, be careful not to crimp the wires between the insulators and sealant.
10. Align the follower and body to create a full keyway.
11. Place the pin in the keyway.
12. Thread the cap on finger tight.
13. Secure the gland body into a vice.
14. Adjust the wires to the correct position.
15. Using a torque wrench, tighten the cap to the specified torque (see chart).
16. The assembly is now ready for use. Apply a wrench to the gland body flats – not the cap – for mounting to the vessel.

### For assembly directly into a vessel:

1. Verify that the total length of wire/probes provides a sufficient length for your desired immersion and leads.
2. Mount the gland body into the vessel wall. This may be done by threading or welding, depending on the mounting style. When using a weld mount, the gland must be disassembled prior to welding to protect the sealant.
3. Thread the cap over the wires.
4. Thread the follower over the wires so that the keyway faces the cap.
5. Thread on insulator #2 (see diagram).
6. Be sure you are using the correct sealant for your working pressure and temperature. Thread on the sealant with the cone facing the process.
7. Thread on insulator #1.
8. Pass the process side of the wires/probes through the body.
9. Slide the insulators, sealant and follower into the body.
10. Push on the follower until the sealant and insulators are firmly seated. For wire assemblies, be careful not to crimp the wires between the insulators and sealant.
11. Align the follower and body to create a full keyway.
12. Place the pin in the keyway.
13. Thread the cap on finger tight.
14. Adjust the wires to the correct position.
15. Apply a backer wrench to the gland body wrench flats to prevent rotation during torquing.
16. While holding the backer wrench firmly in place, use a torque wrench to tighten the cap to the specified torque (see chart).
17. The assembly is now ready for use.

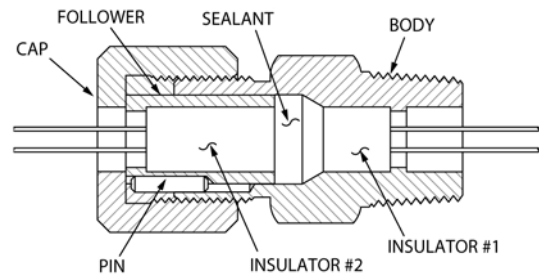

## MHC Series Torque Requirements

Catalog Number	Neoprene		Viton		Teflon		Lava		Grafoil	
	(ft-lbs)	(N-m)	(ft-lbs)	(N-m)	(ft-lbs)	(N-m)	(ft-lbs)	(N-m)	(ft-lbs)	(N-m)
MHC1	20-25	27-34	20-25	27-34	20-25	27-34	30-35	40-47	25-30	27-34
MHC2-020	25-30	34-40	25-30	34-40	30-35	40-47	40-45	61-68	35-40	47-54
MCH2-032	25-30	34-40	25-30	34-40	30-35	40-47	40-45	61-68	35-40	47-54
MHC2-040	25-30	34-40	25-30	34-40	30-35	40-47	40-45	61-68	40-45	61-68
MHC2-062	25-30	34-40	25-30	34-40	30-35	40-47	40-45	61-68	40-45	61-68
MCH4	45-50	61-68	45-50	61-68	50-55	68-74	125-140	170-190	90-100	122-136
MHC5	75-85	102-115	75-85	102-115	75-85	102-115	200-220	272-299	150-165	204-224
MHC5-032-24	N/O	N/O	95-100	129-136	95-100	1129-136	300-310	408-422	250-265	340-360

## PL Series:

PL glands are shipped from the factory already torqued to the correct value and ready for installation. These instructions are provided in the event you choose to disassemble and reassemble the gland. Weld mount styles are shipped untorqued as the gland must be disassembled prior to welding to protect the sealant. PL glands are provided with Teflon sleeves on the body and cap to protect against wire chafing. Do not remove these sleeves.

When using a Grafoil sealant, the insulators on PL glands are chamfered around the holes. Insulators for other sealants are not chamfered. Do **not** interchange.

### For assembly separate from the vessel:

1. Verify that the total length of wire provides a sufficient length for your desired immersion and leads.
2. Thread on insulator #1 (see diagram).
3. Be sure you are using the correct sealant for your working pressure and temperature. Thread on the sealant with the cone facing the process.
4. Thread on insulator #2.
5. Slide on the follower, so that the keyway faces the cap.
6. Pass the process side of the wires through the body.
7. Push on the follower until the sealant and insulators are firmly seated. Be careful not to crimp the wires between the insulators and sealant.
8. Align the follower and body to create a full keyway.
9. Place the pin in the keyway.
10. Thread the cap on finger tight.
11. Secure the gland body into a vice.
12. Adjust the wires to the correct position.
13. Using a torque wrench, tighten the cap to the specified torque (see chart).
14. The assembly is now ready for use. Apply a wrench to the gland body flats – not the cap – for mounting to the vessel.

### For assembly directly into a vessel:

1. Verify that the total length of wire provides a sufficient length for your desired immersion and leads.
2. Mount the gland body into the vessel wall. This may be done by threading or welding, depending on the mounting style. When using a weld mount, the gland must be disassembled prior to welding to protect the sealant.
3. Thread on insulator #1 (see diagram).
4. Be sure you are using the correct sealant for your working pressure and temperature. Thread on the sealant with the cone facing the process.
5. Thread on insulator #2.
6. Slide on the follower, so that the keyway faces the cap.
7. Pass the process side of the wires through the body.
8. Push on the follower until the sealant and insulators are firmly seated. Be careful not to crimp the wires between

the insulators and sealant.

9. Align the follower and body to create a full keyway.
10. Place the pin in the keyway.
11. Thread the cap on finger tight.
12. Adjust the wires to the correct position.
13. Apply a backer wrench to the gland body flats to prevent rotation during torquing.
14. While holding the backer wrench firmly in place, use a torque wrench to tighten the cap to the specified torque (see chart).
15. The assembly is now ready for use.

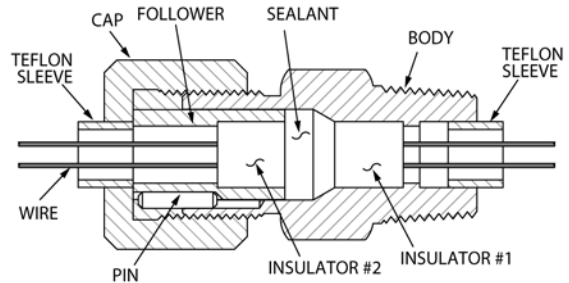

### PL Series Torque Requirements

	Number of Holes	Grafoil		Teflon	
		(ft-lbs)	(N-m)	(ft-lbs)	(N-m)
PL-20	2,3,4	90-100	122-136	60-70	81-95
PL-20	6,8	150-165	204-224	90-100	122-136
PL-20	18	250-265	340-360	125-140	170-190
PL-18	1	20-30	27-40	12-15	16-20
PL-18	2,3,4	90-100	122-136	60-70	81-95
PL-18	6,8	150-165	204-224	90-100	122-136
PL-18	10,12	250-265	340-360	125-140	170-190
PL-16	2,3,4	90-100	122-136	60-70	81-95
PL-16	6,8	150-165	204-224	90-100	122-136
PL-16	10,12	250-265	340-360	125-140	170-190
PL-14	1	25-30	34-40	12-15	16-20
PL-14	2	90-100	122-136	60-70	81-95
PL-14	3,4,6,8	150-165	204-224	90-100	122-136
PL-14	10,12	250-265	340-360	125-140	170-190
PL-12	2,3,4,6	150-165	204-224	90-100	122-136
PL-10	2,3,4	150-165	204-224	80-90	108-122
PL-8	2	150-165	204-224	75-85	102-115
PL-8	3	250-265	340-360	125-140	170-190

Minimum recommended wire bend radius - 10 times the wire diameter

## MHM Series For Hex-Style Models MHM2-MHM5

### For assembly separate from the vessel:

1. Verify that the probe length is sufficient for your desired immersion.
2. Thread the cap over the probes with the female thread facing the process (see diagram).
3. Thread the follower over the probes with the keyway towards the cap.
4. Be sure you are using the correct sealant for your working pressure and temperature. Thread the sealant over the probes with the cone facing the process.
5. Thread the seat over the probes with the concave side facing the sealant.
6. Thread the gland body over the probes.
7. Push on the follower until the sealant and seat are firmly positioned in the gland body.
8. Align the follower and body to create a full keyway.
9. Place the pin in the keyway.
10. Thread the cap on finger tight.
11. Secure the gland body into a vice.
12. Make the final adjustment of immersion length.
13. Using a torque wrench, tighten the cap to the specified torque (see chart).
14. The assembly is now ready for use. Apply a wrench to the gland body flats – not the cap – for mounting to the vessel.

### For assembly directly into a vessel:

1. Verify that the probe length is sufficient for your desired immersion.
2. Mount the gland body into the vessel wall. This may be done by threading or welding, depending on the mounting style. When using a weld mount, the gland must be disassembled prior to welding to protect the sealant.
3. Thread the cap over the probes with the female thread facing the process (see diagram).
4. Thread the follower over the probes with the keyway towards the cap.
5. Be sure you are using the correct sealant for your working pressure and temperature. Thread the sealant over the probes with the cone facing the process.
6. Thread the seat over the probes with the concave side facing the sealant.
7. Insert the probes through the body into the process.
8. Push on the follower until the sealant and seat are firmly positioned in the gland body.
9. Align the follower and body to create a full keyway.
10. Place the pin in the keyway.
11. Thread the cap on finger tight.
12. Make the final adjustment of immersion length.
13. Apply a backer wrench to the gland body flats to prevent rotation during torquing.

14. While holding the backer wrench firmly in place, use a torque wrench to tighten the cap to the specified torque (see chart).
15. The assembly is now ready for use.

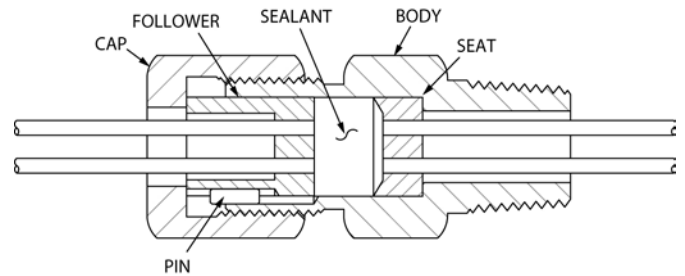

## MHM Series For Flange-Cap Model MHM6

### For assembly separate from the vessel:

1. Verify that the probe length is sufficient for your desired immersion.
2. Thread the flange/cap over the probes (see diagram).
3. Thread the follower over the probes with the counterbore towards the cap.
4. Be sure you are using the correct sealant for your working pressure and temperature. Thread the sealant over the probes with the cone facing the process. (Sealant may be in more than one layer.)
5. Thread the seat over the probes with the concave side facing the sealant.
6. Thread the gland body over the probes.
7. Push on the follower until the sealant and seat are firmly positioned in the gland body.
8. Slide the flange/cap into place after the follower.
9. Thread the 6 cap screws in place and finger tighten.
10. Secure the gland body into a vice.
11. Make the final adjustment of immersion length.
12. Using a torque wrench, tighten the cap screws to 30-35 ft.- lbs. (40-47 N-m) per bolt. The cap screws should be progressively tightened in the order 1-4-2-5-3-6.
13. The assembly is now ready for use. Apply a wrench to the gland body flats for mounting to the vessel.

### For assembly directly into a vessel:

1. Verify that the probe length is sufficient for your desired immersion.
2. Mount the gland body into the vessel wall. This may be done by threading or welding, depending on the mounting style. When using a weld mount, the gland must be disassembled prior to welding to protect the sealant.
3. Thread the flange/cap over the probes (see diagram).
4. Thread the follower over the probes with the counterbore towards the flange/cap.



- Be sure you are using the correct sealant for your working pressure and temperature. Thread the sealant over the probes with the cone facing the process. (Sealant may be in more than one layer.)
- Thread the seat over the probes with the concave side facing the sealant.
- Insert the assembly through the body.
- Push on the follower until the sealant and seat are firmly positioned in the gland body.
- Slide the flange/cap into place to contact the follower.
- Thread the 6 cap screws in place and finger tighten.
- Make the final adjustment of immersion length.
- Use a torque wrench to tighten the cap screws to 30-35 ft-lbs (40-47 N-m) per bolt. The cap screws should be progressively tightened in the order 1-4-2-5-3-6.
- The assembly is now ready for use.

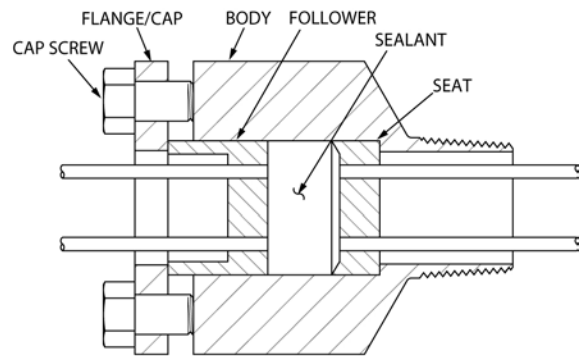

### MHM Series Torque Requirements

Catalog Number	Neoprene		Viton		Teflon		Lava		Grafoil	
	(ft-lbs)	(N-m)	(ft-lbs)	(N-m)	(ft-lbs)	(N-m)	(ft-lbs)	(N-m)	(ft-lbs)	(N-m)
MHM2	25-30	34-40	25-30	34-40	25-30	34-40	25-30	34-40	25-30	34-40
MHM4	80-90	108-123	80-90	108-123	80-90	108-123	125-140	170-190	110-120	150-163
MHM5	120-130	163-176	120-130	163-176	150-165	204-224	200-220	272-299	175-190	238-258

### For Split Glands – SPG and DSPG Series

#### For assembly separate from the vessel:

- Verify that the probe length is sufficient for your desired immersion.
- Secure the gland body into a vice.
- Thread the cap over the probes/wires with the female thread facing the process (see diagram).
- Insert the probes/wires through the body.
- Assemble the mating halves or quarters of the seat around the probes/wires with the concave side facing away from the process.
- Slide the assembled seat into the body.
- Be sure you are using the correct sealant for your working pressure and temperature. Assemble the mating halves or quarters of the sealant around the probes/wires with the cone facing the process. Grafoil sealants are numbered sequentially and must be assembled in sequence.
- Slide the assembled sealant into the body.
- Assemble the mating halves or quarters of the follower around the probes/wires with the keyway facing the cap.

- Slide the assembled follower into the body.
- Push on the follower until the sealant and seat are firmly positioned in the gland body.
- Align the follower and body to create a full keyway.
- Place the pin in the keyway.
- Thread the cap on finger tight.
- Make the final adjustment of immersion length.
- Using a torque wrench, tighten the cap to the specified torque (see chart).
- The assembly is now ready for use. Apply a wrench to the gland body flats – not the cap – for mounting to the vessel.

#### For assembly directly into a vessel:

- Verify that the probe length is sufficient for your desired immersion.
- Mount the gland body into the vessel wall. This may be done by threading or welding, depending on the mounting style. When using a weld mount, the gland must be disassembled prior to welding to protect the sealant.

### SPG/DSPG Series Torque Requirements

Catalog Number	Viton		Teflon		Lava		Grafoil	
	(ft-lbs)	(N-m)	(ft-lbs)	(N-m)	(ft-lbs)	(N-m)	(ft-lbs)	(N-m)
SPG75	25-30	34-40	25-30	34-40	25-30	34-40	N/O	N/O
DSPG75	25-30	34-40	25-30	34-40	25-30	34-40	N/O	N/O
SPG100	80-90	108-122	80-90	108-122	125-140	170-190	110-120	150-163
DSPG100	80-90	108-123	80-90	108-123	125-140	170-190	110-120	150-163
SPG150	120-130	163-176	150-165	204-224	200-220	272-299	175-225*	238-306
DSPG150	120-130	163-176	150-165	204-224	200-220	272-299	175-225*	238-306

\* When applying torque to SPG150 and DSPG150 models with 0.40" diameters or less containing Grafoil Sealants, torque to 200 ft.-lbs., then retorquing to 225 ft. - lbs. after 24 hours.

3. Thread the cap over the probes/wires with the female thread facing the process (see diagram).
4. Insert the probes/wires through the body.
5. Assemble the mating halves or quarters of the seat around the probes/wires with the concave side facing away from the process.
6. Slide the assembled seat into the body.
7. Be sure you are using the correct sealant for your working pressure and temperature. Assemble the mating halves or quarters of the sealant around the probes/wires with the cone facing the process.
8. Slide the assembled sealant into the body.
9. Assemble the mating halves or quarters of the follower around the probes/wires with the keyway facing the cap.
10. Slide the assembled follower into the body.
11. Push on the follower until the sealant and seat are firmly positioned in the gland body.
12. Align the follower and body to create a full keyway.
13. Place the pin in the keyway.
14. Thread the cap on finger tight.

15. Make the final adjustment of immersion length.
16. Apply a backer wrench to the gland body flats to prevent rotation during torquing.
17. While holding the backer wrench firmly in place, use a torque wrench to tighten the cap to the specified torque (see chart).
18. The assembly is now ready for use.

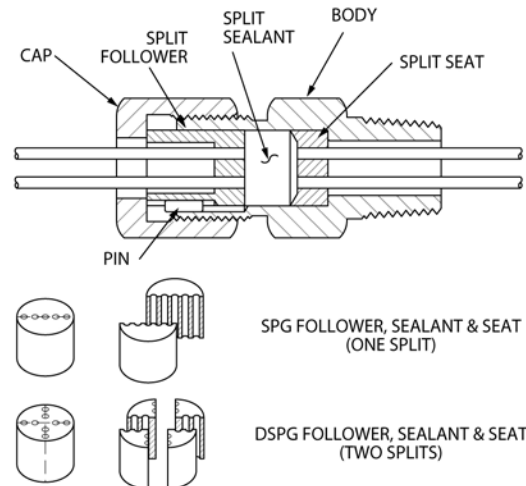

## For Split Glands – PGS Series

### For assembly separate from the vessel:

1. Verify that the probe length is sufficient for your desired immersion.
2. Secure the gland body into a vice.
3. Thread the cap over the probe with the female thread facing the process (see diagram).
4. Insert the probe through the body.
5. Assemble the mating halves of the seat around the probe with the concave side facing away from the process.
6. Slide the assembled seat into the body.
7. Be sure you are using the correct sealant for your working pressure and temperature. Assemble the mating halves of the sealant around the probe with the cone facing the process.
8. Slide the assembled sealant into the body.
9. Assemble the mating halves of the follower around the probe with the counterbore facing the cap.
10. Slide the assembled follower into the body.
11. Push on the follower until the sealant and seat are firmly positioned in the gland body.
12. Thread the cap on finger tight.
13. Make the final adjustment of immersion length.
14. Using a torque wrench, tighten the cap to the specified torque (see chart).
15. The assembly is now ready for use. Apply a wrench to the gland body flats – not the cap – for mounting to the vessel.

### For assembly directly into a vessel:

1. Verify that the probe length is sufficient for your desired immersion.
2. Mount the gland body into the vessel wall. This may be done by threading or welding, depending on the mounting style. When using a weld mount, the gland must be disassembled prior to welding to protect the sealant.
3. Thread the cap over the probe with the female thread facing the process (see diagram).
4. Insert the probe through the body.
5. Assemble the mating halves of the seat around the probe with the concave side facing away from the process.
6. Slide the assembled seat into the body.
7. Be sure you are using the correct sealant for your working pressure and temperature. Assemble the mating halves of the sealant around the probe with the cone facing the process.
8. Slide the assembled sealant into the body.
9. Assemble the mating halves of the follower around the probe with the counterbore facing the cap.
10. Slide the assembled follower into the body.
11. Push on the follower until the sealant and seat are firmly positioned in the gland body.
12. Thread the cap on finger tight.
13. Make the final adjustment of immersion length.
14. Apply a backer wrench to the gland body flats to prevent rotation during torquing.
15. While holding the backer wrench firmly in place, use a torque wrench to tighten the cap to the specified torque (see chart).
16. The assembly is now ready for use.

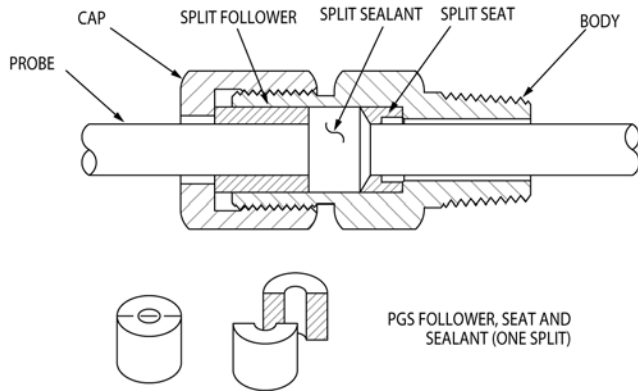

## PGS Series Torque Requirements

Gland Series	Viton		Teflon		Lava		Grafoil	
	(ft-lbs)	(N-m)	(ft-lbs)	(N-m)	(ft-lbs)	(N-m)	(ft-lbs)	(N-m)
PG2S	30-35	40-47	15-20	20-27	40-45	54-61	35-40	47-54
PG4S	55-60	74-81	55-60	74-81	125-140	170-190	90-100	122-136
PG5S	55-60	74-82	90-100	122-136	200-220	272-299	90-100	122-137

## For BSWS Series

1. Identify the type of gland to be assembled. If the sensor leads have an outer jacket or braid, trim this back to the point where it will enter the gland body when installed (see diagram). This will expose the individual insulated leads.
2. Install the sensor securely in its housing. Place the gland body over the leads and mount it in the enclosure or bearing housing mounting thread.
3. Slide the sealant with the cone facing the process over the leads into the gland body until seated. Individual holes are provided for each lead.
4. Slide the follower over the leads and insert it into the gland body. Ensure that the wires are correctly positioned.
5. Place the cap over the leads and finger tighten.
6. Make the final adjustment of lead length.
7. Apply a backer wrench to the gland body flats to prevent rotation during torquing.
8. While holding the backer wrench firmly in place, use a torque wrench to tighten the cap to the specified torque (see chart).
9. The assembly is now ready for use.

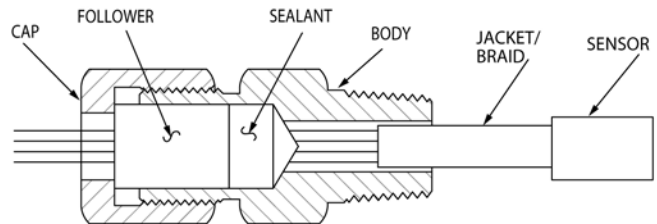

## BSWS Series Torque Requirements

Catalog Number	Viton	
	(ft-lbs)	(N-m)
BSWS4	3-5	4-6
BSWS5	12-15	16-20

## Lubricant Application Instructions

Conax Technologies sealing glands have lubricant applied at the factory. Substitution of factory-supplied lubricant will affect seal integrity. Lubrication prevents thread galling and minimizes friction between mating metallic components to maximize sealing gland performance when a catalog-specified torque is applied. Lubrication should be used any time a sealing gland assembly is opened for replacement or adjustment of the probe(s), wires or sealant. By re-lubricating the gland body threads and load bearing surface of the cap, proper load transfer (sealant compression) can be achieved.

Lubricant kits are available from Conax Technologies in convenient, single application, disposable packages with the applicator included. Conax Technologies recommends use of this lubricant to ensure gland performance.

### Hex-Style Sealing Glands MK Series

1. Apply a small amount of lubricant, a tear drop equivalent, in two to three places, equally spaced, to the ferrule top. Refer to Figure 1.
2. Apply a single line of lubricant to the full length of the straight thread on the cap. Refer to Figure 1.
3. Assemble the sealing gland per MK sealing gland instructions.

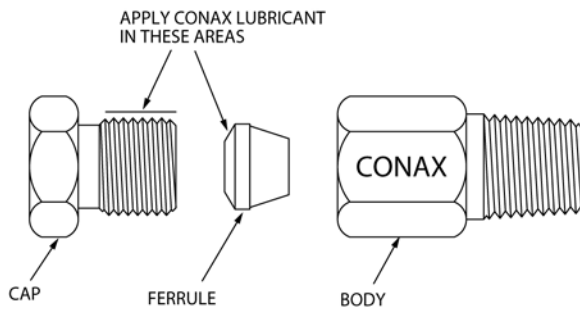

Figure 1

### PG, MHM, MHC, TG, PL, EG, EGT, SPG, DSPG, PGS and BSWS Series

1. Apply a small amount of lubricant, tear drop equivalent, in two to three places, equally spaced, to the top of the follower. Do not allow the lubricant to directly contact the sealant or the elements you are sealing. Refer to Figure 2.

2. Apply a single line of lubricant to the full length of the straight thread on the gland body. Refer to Figure 2.
3. Assemble the sealing gland per applicable sealing gland instructions.

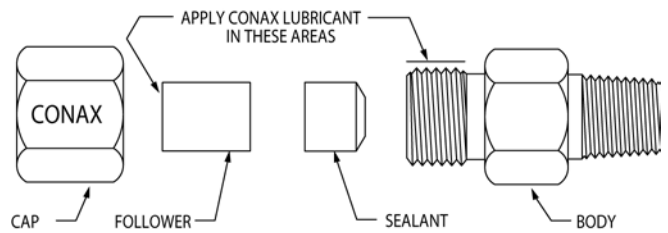

Figure 2

### Flange-Cap Style Sealing Glands PG, MHM, EG and EGT Series

1. Apply a small amount of lubricant, tear drop equivalent, in two to three places, equally spaced, to the underside of the hex cap screw on each of the six (6) hex cap screws. Do not allow the lubricant to directly contact the sealant or the elements you are sealing. Refer to Figure 3.
2. Apply a single line of lubricant to the full thread length on each of the six (6) hex head screws. Refer to Figure 3.
3. Assemble the sealing gland. Apply torque per applicable gland chart.

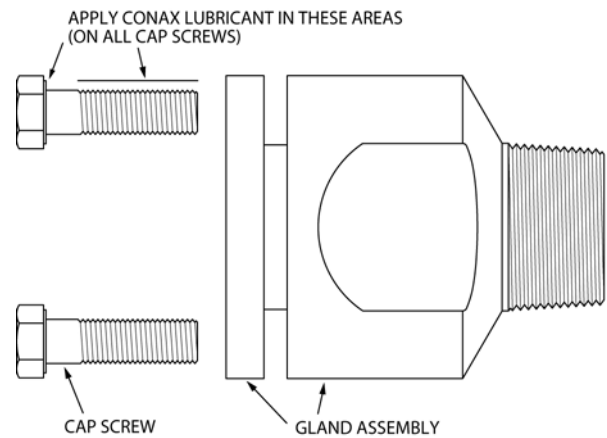

Figure 3

CAUTION: Lubricant may cause mild eye irritation. Do not use for lubrication of aluminum or magnesium parts.

This product is not an OSHA hazardous material, as defined in 29 CFR 1910.120. This product contains CAS #9002839, Ethene, chlorotrifluoro-homopolymer. 24-Hour Emergency Phone 1-800-733-3665. HMIS Rating System: Health 0, Flammability 0, Reactivity 1. For industrial use only.



2300 Walden Avenue • Buffalo, New York 14225  
FAX: 716-684-7433 • Phone: 716-684-4500 • 1-800-223-2389  
e-mail: [info@conaxtechnologies.com](mailto:info@conaxtechnologies.com)

[www.conaxtechnologies.com](http://www.conaxtechnologies.com)



Conax Technologies is a registered trademark of Conax Technologies. Teflon is a registered trademark of E.I. DuPont de Nemours Company.  
Viton is a registered trademark of Dupont Dow Elastomers, LLC. Grafoil is a registered trademark of UCAR International, Inc.  
PEEK is a registered trademark of Victrex plc.