

Please download PDF and fill in the boxes. Return form to sales@thermal-detection.com or fax to +44 1642 618307

Name: _____ Email: _____
 Organisation: _____ Tel: _____
 Country _____

Section 1 - unit dimensions (in mm)

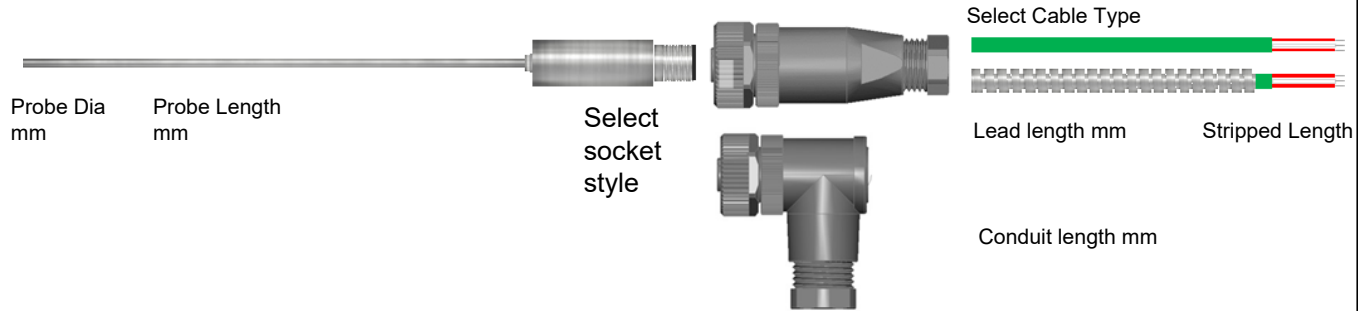

Section 2 - Sensor Configuration

	PT100 Type	
Sensor Number	Type	Wires
Single	Class 'A'	2 wire
Duplex	1/3 DIN	3 wire
	1/10 DIN	4 wire
		Transmitter? No Transmitter?
		Min / Max Range °C

Section 3 - Optional Features (in mm)

Reduced Probe Tip

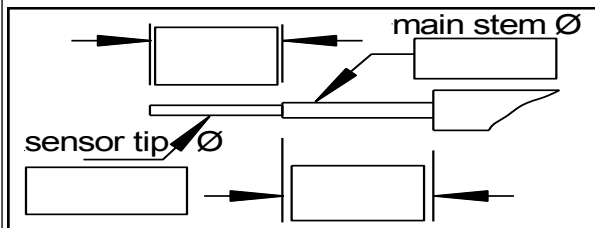

Bend in Probe

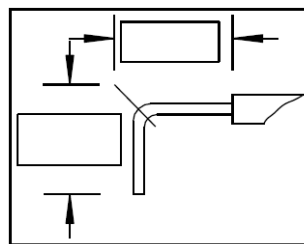

Process Connection

- Fixed Thread
- Compression Fitting
- Tri-Clover
- Thread / Tri-clover type and size

Chisel Pointed Tip



Section 4 - Application Details

Number of probes required	Additional information
Industry Type	